

PIPE SLIDE SETS (GUIDES)

Model SS

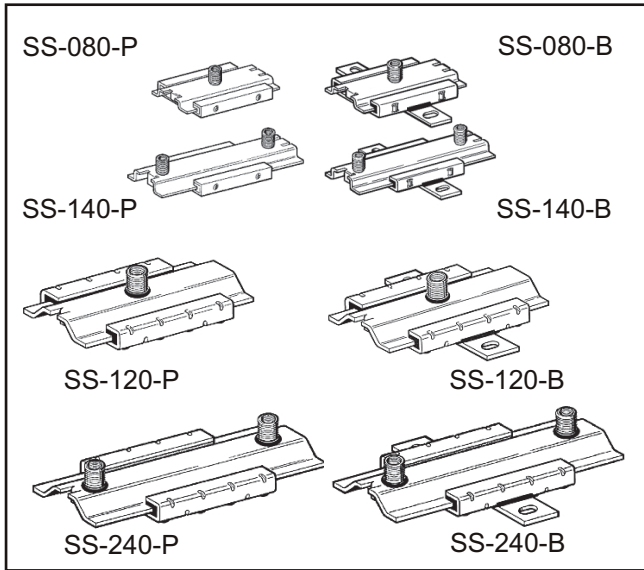

APPLICATIONS

These slide sets (guides) consist of a slider with one or two multi-threaded fixings for pipe clips of your choice, and a guide base with low friction slide rails, with or without a back plate bracket, for bolting directly to floors, ceilings and walls, or to channels using a channel nut and hexagon bolt.

Pipe clips used with these slide sets can be selected to suit steel, stainless steel, copper, plastic or composite pipes and can be used accordingly for the following applications:-

- Low Temperature Heating (LTHW)
- Medium Temp. Heating (MTHW)
- High Temp. Heating (HTHW)
- Domestic Hot Water (DHWS)
- Steam and Condensate

Typical Pipe Size	Linear Travel (mm)	Maximum Force (N)	Slider Length (mm)	Bolt Hole Diameter (mm)	Pipe Clip Fixing	Product Code (MODEL-MVT-FIXING)
Up to DN100 Up to DN100	80 80	2300 2300	130 130	13 13	M10 and M16 M10 and M16	SS-080-P SS-080-B
Up to DN100 Up to DN100	140 140	2300 2300	200 200	13 13	M10 and M16 M10 and M16	SS-140-P SS-140-B
Up to DN150 Up to DN150	120 120	5000 5000	150 150	13 13	M12, M16 and 1/2" M12, M16 and 1/2"	SS-120-P SS-120-B
Up to DN150 Up to DN150	240 240	5000 5000	275 275	13 13	M12, M16 and 1/2" M12, M16 and 1/2"	SS-240-P SS-240-B
NOTE This is typical of use with 10bar Axial Expansion Joints The pipe must not impose sideways forces greater than the Maximum Force		NOTE This is taken as the sideways force at the slide rail only A smaller maximum force applies at increased distance from the slide rail as shown below				

SPECIFICATION

SS-080 - a plated steel formed slider with one dual-drilled fixing to suit M10 male or M16 female and M16 locking nut. Complete with BZP steel guide base with low friction slide rails.

SS-140 - as above, but the slider has two dual-drilled fixings and has a longer slider for more travel.

SS-120 - a plated steel formed slider with one triple-drilled fixing hole to suit M12 and M16 male or 1/2" female and 1/2" locking nut. Complete with BZP steel guide base with low friction slide rails.

SS-240 - as above, but the slider has two triple-drilled fixings and has a longer slider for more travel.

All models are available either plain or with a backplate bracket.

Also available manufactured from stainless steel or with HCP finish. Connection adaptors, studs, tubes and pipe clips can be supplied.

OPERATING PARAMETERS

SS-080 and SS-140 models
 Upper Temperature Limit = 130 °C
 Coefficient of Static Friction = 0.18
 Maximum Sideways Force at:
 50mm from underside of base = 600N
 100mm from underside of base = 300N

SS-120 and SS-240 models
 Upper Temperature Limit = 130 °C
 Coefficient of Static Friction = 0.18
 Maximum Sideways Force at:
 50mm from underside of base = 3500N
 100mm from underside of base = 1750N

The maximum force in the table is to be taken as the maximum sideways force and must include the dead weight of the pipe when used on horizontal pipe runs. Always be aware that the bending moments of threaded rods or tubes may restrict the application.