

UNIVERSAL EXPANSION JOINTS (B.M.J.s)

Model EJUF + EJUFN

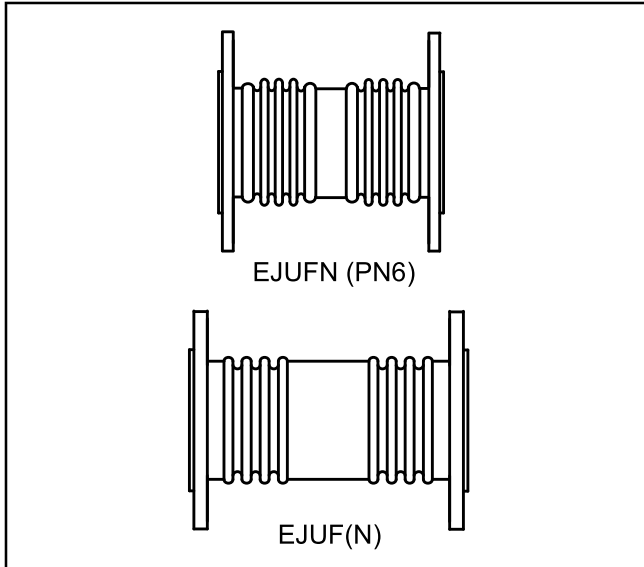

APPLICATIONS

Universal expansion joints (building movement joints) are designed to accommodate structural movements imposed on pipes in any direction. They rely on the pipe entering and leaving the device being firmly anchored to the building structure at the respective sides of the structural movement line.

These models have either mixed carbon steel / stainless steel internal parts OR stainless steel to ALL wetted parts, and can be used accordingly on steel, stainless steel or copper flanged pipe systems for the following applications:-

- Low Temperature Heating (LTHW)
- Medium Temp. Heating (MTHW)
- Chilled Water (CHW)
- Condenser Water (Cond.W)
- Domestic Hot Water (DHWS)
- Boosted Cold Water (BCWS)

Nominal Size DN (mm)	Installation Length (mm)	Max' Lateral Movement (mm)	Max' Axial Movement (mm)	Spring Rates (N/mm)	Product Code (MODEL-SIZE-OAL-ENDS)
50	341	+/-50.5	+/-22.0	5.2 LAT. / 82 AX.	EJUFN-050-341-PN6
65	341	+/-48.0	+/-27.5	7.8 LAT. / 78 AX.	EJUFN-065-341-PN6
80	364	+/-51.0	+/-30.5	8.7 LAT. / 77 AX.	EJUFN-080-364-PN6
100	385	+/-49.5	+/-36.5	20 LAT. / 126 AX.	EJUFN-100-385-PN6
125	413	+/-50.5	+/-42.0	26 LAT. / 123 AX.	EJUFN-125-413-PN6
150	430	+/-50.5	+/-48.0	33 LAT. / 120 AX.	EJUFN-150-430-PN6
200	470	+/-49.5	+/-50.0	44 LAT. / 136 AX.	EJUFN-200-470-PN6
250	410	+/-33.0	+/-60.0	120 LAT. / 129 AX.	EJUFN-250-410-PN6
300	430	+/-25.0	+/-50.0	108 LAT. / 96 AX.	EJUFN-300-430-PN6
50					EJUF(N)-050
65					EJUF(N)-065
80					EJUF(N)-080
100					EJUF(N)-100
125					EJUF(N)-125
150					EJUF(N)-150
200					EJUF(N)-200
250					EJUF(N)-250
300					EJUF(N)-300

These are designed individually for simultaneous movement directions, particularly for known movement magnitudes at specific pressures and temperatures.

SPECIFICATION

EJUF - Flanged model with stainless steel bellows and carbon steel intermediate tube and fixed flanges.

EJUFN - Flanged model with stainless steel bellows, intermediate tube and carbon steel flanges with stainless steel van-stone facing (lapped pipe end).

Designed to EJMA* Standards. *Expansion Joint Manufacturers Association.

BS6129 Part 1 applies to the installation.

Conforms with PED* 97/23/EC. *Pressure Equipment Directive.

OPERATING PARAMETERS

Flanged models to EN1092 PN6

- Operating Temperature, TS = 110 °C.
- Operating Pressure, PS = 6 Barg.
- Cold Test Pressure, PT = 9 Barg.

These models are designed for simultaneous movement. Combinations of +/-lateral and +/-axial movement from the table must not exceed 100%. E.g. for EJUFN-050-341-PN6: 70% of +/-22 = +/-15.40mm and 30% of +/-50.5 = +/-15.15mm
50% of +/-22 = +/-11.00mm and 50% of +/-50.5 = +/-25.25mm

Bespoke models are designed to suit the pressure and temperature of the fluid conveyed in compliance with PED 97/23/EC. As a guide, the operating parameters are based on pressure / temperature (p/T) ratings for material group 1E1 ferritic steel flanges from EN1092, where the operating pressure is reduced at elevated operating temperatures.

Operating Temp.	Maximum non-shock Operating Pressure for	PN6	PN10	PN16	PN25
Up to 50 °C.	6.0 Barg.	10.0 Barg.	16.0 Barg.	25.0 Barg.	
100 °C.	4.8 Barg.	8.0 Barg.	12.8 Barg.	20.0 Barg.	
150 °C.	4.5 Barg.	7.5 Barg.	11.9 Barg.	18.7 Barg.	
200 °C.	4.1 Barg.	6.9 Barg.	11.0 Barg.	17.2 Barg.	